

# HEAT PUMPS

## Equipped with the Award Winning *Comfort Control System™*

- Increased Reliability
- On-Board Diagnostics
- Fault Recall
- *Active Protection™*



# RUUD ULTRA Series

The Ruud *Ultra Series™* UPRL- JEZ Two-Stage Heat Pump Outdoor Units can provide year-round heating and cooling comfort for residential, multi-family and light commercial applications. They are designed to operate with Ruud indoor units with cooling and heating capacities certified under the ARI Certification program.

These units also contain the most advanced alternate refrigerant which contains no chlorofluorocarbons (CFCs), or hydrochlorofluorocarbons (HCFCs), or other compounds that may leak from air-conditioning systems and potentially harm the protective ozone layer of the Earth's atmosphere.

The Ruud *Ultra Series™* UHPL- Air Handler, equipped with auxiliary heating elements for supplementary heat was designed especially for use with *Ultra Series™* heat pumps. Together they provide systems capable of delivering a maximum HSPF (Heating Seasonal Performance Factor) of 9.50 in the heating mode or a maximum standard S.E.E.R. (Seasonal Energy Efficiency Ratio) of 17.00 in the cooling mode.

The following additional features, plus its energy-saving characteristics, make the UPRL- JEZ Heat Pump outdoor unit an excellent choice for new construction or upgrading your present system.

- The *Comfort Control System™* provides on-board diagnostics and fault history for heat pump units with single-phase compressors by detecting system and electrical problems without adding sensors. It can also communicate "fault codes" to enabled "L terminal" thermostats. The integrated diagnostics with *Active Protection* prevents compressor operation when damage would occur.
- 7-Segment LED Display is exclusive only to Ruud products. The information-display quickly and accurately shows technicians the source of malfunctions.
- Dependable Two-Stage Scroll® Compressor for precise temperature control providing ultimate comfort.
- Attractive, louvered wrap-around jacket protects coil from weather extremes and yard hazards. Top grille is steel reinforced for extra strength. Cabinet is powder painted for all weather protection.
- Exclusive Combination Grille/Motor Mount secures the fan motor to the underside of the discharge grille. The grille protects the motor windings and bearings from rain and snow.
- Features a ten-year conditional unit replacement warranty when properly installed with a new Ruud *Ultra Series™* Air Handler or Ruud Indoor Coil with a Ruud *Ultra Series™* Gas Furnace. See product warranty card for additional information.
- All controls are accessible by removing one service panel. Removable top grille provides access to the outdoor fan motor and outdoor coil.
- Compressor compartment offers additional protection from the elements and reduces operating noise.
- GE® ECM fan motor is designed for low speed, quieter, energy-saving operation.
- Non-cycling reversing valve and demand defrost.
- All models meet or exceed a 1000-hour salt spray test per ASTM B117 Standard Practice for Operating Salt Spray Testing Apparatus.
- Dual-Fuel capable with select thermostats.
- The following "3 Heat/2 Cool" Ruud Thermostats are recommended for maximum comfort: UHC-TST302UNMS, UHC-TST303UNMS or UHC-TST402DFMS.



## UPRL- JEZ Two-Stage Four Models

Efficiencies ranging up to 17 SEER in certain matched systems.  
Nominal Sizes 2, 3, 4 & 5 Tons  
[7.03, 10.5, 14.07 & 17.6 kW]

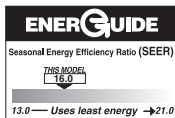

# FEATURES & BENEFITS OF THE *COMFORT CONTROL SYSTEM*™

- The Ruud Exclusive 7 Segment LED Display easily shows system status codes and conditions.

- A Sealed Switch replaces the standard contactor and features optical control and latching mechanism. The sealed switch prevents infiltration of insects and dust. A minimal switching arc, by the optical control, offers greater reliability. The latching mechanism consumes less power while reducing chatter.



- The Status Indication and System Diagnostics feature thermostat communication capability, built-in diagnostics, high & low voltage monitoring and high & low switch monitoring.

The thermostat communication capability alerts the homeowner of any necessary service requirements. Faster, more accurate service is provided with the built-in diagnostics, by providing the HVAC professional with dependable information. Compressor reliability is increased with the high and low voltage monitoring feature. In addition, high and low pressure-switch monitoring prevents the system from operating when damage could occur.



- The Fault Recall feature will allow for the last six fault-codes to be displayed, and will retain these codes even if power failure occurs.
- Built-in short-cycle protection allows the compressor to restart easily without removing the oil from the compressor.
- A 30-second minimum run-time for every compressor call allows the oil to return to the compressor.
- *Active Protection* prevents the compressor from operating if damage could occur.
- The compressor and fan are controlled independently, which reduces the starting load and light dimming.
- A manual push-button is offered to operate the compressor and fan for 5 seconds to allow for an operation check.
- In order to save time and money, replacement automotive fuses can be utilized instead of replacing the entire control board.

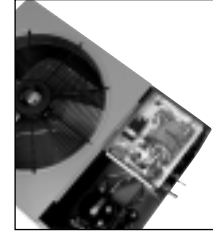

## STANDARD FEATURES

### UPRL- JEZ Heat Pumps

1. 2-stage operation in both cooling and heating mode.
2. Scroll compressor is hermetically sealed and incorporates internal high temperature motor overload protection, and durable insulation on the motor windings. It is externally mounted on rubber grommets to reduce vibration and noise.
3. Compressors have an internal pressure relief assembly to protect against excessive pressure differential.
4. All refrigerant connections are on the exterior of the unit, located close to the ground for neat appearing installations.
5. Cabinet is constructed of powder painted galvanized steel. The full wraparound louvered grille protects the coil from damage.
6. Copper Tube—Aluminum Fin coils are used on all models.
7. The control box is located in the top corner of the cabinet providing for easy access through a service panel.
8. Service valves are standard on all models.
9. Field connections for power and control wiring are kept separate.
10. Every unit is factory charged and run-tested.
11. Separate compressor compartment for easy service access.
12. Drawn, painted base pan for extra corrosion resistance and sound reduction.
13. The **UPRL- JEZ** has a 10 year limited parts warranty, plus a 10 year conditional unit replacement warranty. See the General Terms of Limited Warranty for more details.
14. **Hard Start Kits**—Standard on all JEZ models.
15. Enhanced compressor sound wrap is standard.
16. Control Box Cover.
17. The UPRL- JEZ is shipped with a liquid line filter drier, (not-installed).
18. The UPRL- JEZ features factory-installed auto-reset low and high pressure controls.

## Problem-Solving Accuracy

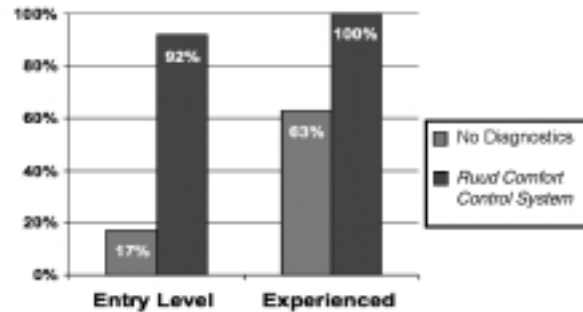

## TWO-STAGE SCROLL® COMPRESSOR

The scroll compressor is the key to efficiency for this Ruud model. It's the latest in high-efficiency compressor technology. The advanced scroll compressor offers low noise and vibration characteristics and features tolerance to liquid refrigerant and system contamination. The scroll also has low start torque, eliminating start problems in the field. And its unique design enables the UPRL- JEZ Heat Pump to perform efficiently, quietly and reliably. All models have a 10-year compressor warranty as standard.



All controls and compressor are accessible for servicing by removal of the service panel.

## Accessories

- Outdoor Thermostats—**  
 RXPT-A01—One outdoor thermostat in box.  
 RXPT-A02—One outdoor thermostat for mounting in box for use with RXPT-A01 or A03.  
 RXPT-A03—One outdoor thermostat with emergency Heat Relay wired and mounted in box.  
 RXPT-A04—Two outdoor thermostats with emergency Heat Relay wired and mounted in box.
- Thermostats**
  - Blower Time Delay Control—**RXMD-C06.
  - Fossil Fuel Kits—**Not required. See Ruud Thermostats Specification Sheet (T22-001).
  - Low Ambient Control—**Cycles outdoor fan to maintain adequate condensing pressures assuring liquid refrigerant flow to the coil. Allows low temperature operation in the cooling cycle down to 0°F [-17.8°C] outdoor temperature. It is recommended that this control be installed in units to be operated at outdoor ambient temperatures under 70°F [21°C] (Model No. RXAD-A08)



**300-Series \***  
Deluxe Programmable



**200-Series \***  
Programmable



**100-Series \***  
Non-Programmable

### 400-Series \* Special Applications/Programmable

Brand	Unique Model Number Prefix	Descriptor (3 Characters)	Series (3 Characters)	System (2 Characters)	Type (2 Characters)
UHC	-	TST	101	GE	MS
UHC=Ruud		TST=Thermostat	100=Non-Programmable	GE=Gas/Oil/Electric	SS=Single-Stage
			200=Programmable	HP=Heat Pump	MS=Multi-Stage
			300=Deluxe Programmable	MD=Modulating Furnace	
			400=Special Applications/Programmable	DF=Dual Fuel	
			UN=Universal AC/HP/GE		

\* Photos are representative. Actual models may vary.

For detailed thermostat match-up information, see specification sheet form number T22-001.

NOTE: Requires “3 Heat/2 Cool” thermostat for Maximum Comfort.

## Model Number Identification

U	P	R	L	—	024	J	E	Z
RUUD	REMOTE HEAT PUMP	EFFICIENCY 16 SEER	DESIGN SERIES R-410A		COOLING CAPACITY	ELECTRICAL DESIGNATION	VARIATIONS E = EQUIPPED WITH THE COMFORT CONTROL SYSTEM™	COOLING CONNECTION FITTING Z = SWEAT W/SCROLL
					024 = 24,000 BTU/HR [7.03 kW] 036 = 36,000 BTU/HR [10.55 kW] 048 = 48,000 BTU/HR [14.07 kW] 060 = 60,000 BTU/HR [17.58 kW]	J = 208/230V-1-6Ø		

[ ] Designates Metric Conversions

## Ruud Heat Pump System

For all season home comfort, performance and energy conservation, choose a Ruud *Ultra Series*™ UPRL- JEZ Series Heat Pump and with an UHPL- Series Air Handler.

More than a reverse cycle air conditioner, it's a specially designed combination Winter/Summer comfort system using an indoor coil for heating and cooling.

To choose an UHPL- Air Handler designed for use with the UPRL- JEZ Heat Pump, refer to the Performance Data Tables and/or the air handler specification sheet.

# Performance Data ARI Standard Conditions

Note: Only these combinations of indoor/outdoor units are approved and any other combinations should not be used.

Outdoor Unit UPRL-	Model Numbers		Stage	ARI Cooling Performance 80° [26.5°C] / 67°F [19.5°C] WB Indoor Air 95°F [35°C] DB Outdoor Air				ARI Ratings		Indoor Airflow CFM [L/s]	Sound Rating dB	Outdoor Air 47°F [8.5°C] DB/ 43°F [6°C] WB		Outdoor Air 17°F [-8.5°C] DB/ 15°F [-9.5°C] WB		DOE Region IV HSPF
	ID Coil	ID Air Mover		Net Sensible BTU/H [kW]	Net Latent BTU/H [kW]	Total Capacity	SEER	EER	BTU/H [kW]			COP	BTU/H [kW]	COP	BTU/H [kW]	
Rev. 3/28/2008	RCSM-H*2421A* ①	UHPL-HM2421	1	14,500 [4.2]	4,100 [1.2]	24,000 [7.0]	17.00	13.05	625 [295]	71	16,600 [4.9]	2.56	9,900 [2.9]	22,200 [6.5]	13,400 [3.9]	9.50
			2	17,850 [5.2]	6,150 [1.8]				800 [378]	74	22,200 [6.5]	3.84	13,400 [3.9]			
			1 - dehumid	13,800 [4.0]	3,700 [1.1]				550 [260]	71						
			2 - dehumid	17,250 [5.1]	6,150 [1.8]				675 [319]	74						
024JEZ	RCFM-H*2417A*	UGFD-067MCK?	1	14,450 [4.2]	4,050 [1.2]	23,800 [7.0]	16.50	12.55	600 [283]	71	16,600 [4.9]	2.54	9,900 [2.9]	22,400 [6.6]	13,600 [4.0]	9.50
		2	17,750 [5.2]	6,050 [1.8]	800 [378]				74	22,400 [6.6]	3.76	13,600 [4.0]				
		UGFD-077MCK?	1	14,450 [4.2]	4,050 [1.2]	24,000 [7.0]	16.50	12.65	600 [283]	71	16,600 [4.9]	2.54	9,900 [2.9]	22,400 [6.6]	13,500 [4.0]	9.50
		2	17,800 [5.2]	6,200 [1.8]	800 [378]				74	22,400 [6.6]	3.78	13,500 [4.0]				
		UGGD-067MCK?	1	14,450 [4.2]	4,150 [1.2]	24,000 [7.0]	17.00	12.85	600 [283]	71	16,600 [4.9]	2.58	9,900 [2.9]	22,200 [6.5]	13,400 [3.9]	9.50
		2	17,850 [5.2]	6,150 [1.8]	800 [378]				74	22,200 [6.5]	3.82	13,400 [3.9]				
		UGGD-077MCK?	1	14,450 [4.2]	4,050 [1.2]	24,000 [7.0]	17.00	12.75	625 [295]	71	16,600 [4.9]	2.56	9,900 [2.9]	22,200 [6.5]	13,500 [4.0]	9.50
		2	17,800 [5.2]	6,200 [1.8]	800 [378]				74	22,200 [6.5]	3.80	13,500 [4.0]				
		UGJD-067MCK?	1	14,450 [4.2]	4,150 [1.2]	24,000 [7.0]	17.00	12.85	600 [283]	71	16,600 [4.9]	2.58	9,900 [2.9]	22,200 [6.5]	13,400 [3.9]	9.50
		2	17,850 [5.2]	6,150 [1.8]	800 [378]				74	22,200 [6.5]	3.82	13,400 [3.9]				
		UGJD-077MCK?	1	14,450 [4.2]	4,050 [1.2]	24,000 [7.0]	17.00	12.75	625 [295]	71	16,600 [4.9]	2.56	9,900 [2.9]	22,200 [6.5]	13,500 [4.0]	9.50
		2	17,800 [5.2]	6,200 [1.8]	800 [378]				74	22,200 [6.5]	3.80	13,500 [4.0]				
UGLR-077AMK?	1	14,500 [4.2]	4,100 [1.2]	24,000 [7.0]	17.00	13.00	600 [283]	71	16,500 [4.8]	2.60	9,800 [2.9]	22,200 [6.5]	13,400 [3.9]	9.50		
2	17,900 [5.2]	6,100 [1.8]	800 [378]				74	22,200 [6.5]	3.84	13,400 [3.9]						
UGPR-057BMK?	1	14,400 [4.2]	4,100 [1.2]	24,000 [7.0]	16.50	12.80	600 [283]	71	17,100 [5.0]	2.56	10,400 [3.0]	22,200 [6.5]	13,500 [4.0]	9.50		
2	17,850 [5.2]	6,150 [1.8]	775 [366]				74	22,800 [6.7]	3.80	13,900 [4.1]						
RCFM-H*2417A*+RXMD-C06	Coil Only		1	13,900 [4.1]	4,100 [1.2]	23,600 [6.9]	14.50	11.65	625 [295]	71	16,600 [4.9]	2.44	9,900 [2.9]	22,800 [6.7]	13,900 [4.1]	8.50
			2	17,450 [5.1]	6,150 [1.8]				775 [366]	74	22,400 [6.6]	3.58	13,500 [4.0]			

① Highest sales volume tested combination required by DOE test procedures.

[ ] Designates Metric Conversions

# Performance Data ARI Standard Conditions (con't.)

Note: Only these combinations of indoor/outdoor units are approved and any other combinations should not be used.

Outdoor Unit UPRL-	Model Numbers		Stage	ARI Cooling Performance										ARI Heating Performance (70°F [21°C] Indoor)						DOE Region IV HSPF								
				80° [26.5°C] / 67°F [19.5°C] WB Indoor Air										Outdoor Air			Outdoor Air											
				95°F [35°C] DB Outdoor Air										47°F [8.5°C] DB / 43°F [6°C] WB		17°F [-8.5°C] DB / 15°F [-9.5°C] WB		47°F [8.5°C] DB / 43°F [6°C] WB			17°F [-8.5°C] DB / 15°F [-9.5°C] WB							
ID Coil	ID Air Mover	Net Sensible BTU/H [kW]	Net Latent BTU/H [kW]	Total Capacity	SEER	EER	Indoor Airflow CFM [L/s]	Sound Rating dB	BTU/H [kW]	COP	BTU/H [kW]	COP	BTU/H [kW]	COP	BTU/H [kW]	COP												
Rev. 3/28/2008			1	UGFD-06?MCK?	14,450 [4.2]	4,050 [1.2]	23,800 [7.0]	16.50	12.55	600 [283]	71	16,600 [4.9]	3.78	9,900 [2.9]	2.54	22,400 [6.6]	2.54	13,500 [4.0]	2.54	22,400 [6.6]	2.54	13,500 [4.0]	2.54	13,500 [4.0]	9.50			
			2	UGFD-07?MCK?	17,750 [5.2]	6,050 [1.8]	24,000 [7.0]	16.50	12.65	800 [378]	74	22,400 [6.6]	3.80	13,500 [4.0]	2.56	22,200 [6.5]	2.56	13,500 [4.0]	2.56	22,200 [6.5]	2.56	13,500 [4.0]	2.56	13,500 [4.0]	9.50			
			1	UGGD-06?MCK?	14,450 [4.2]	4,150 [1.2]	24,000 [7.0]	17.00	12.90	600 [283]	71	16,500 [4.8]	3.84	9,800 [2.9]	2.58	22,200 [6.5]	2.58	13,400 [3.9]	2.58	22,200 [6.5]	2.58	13,400 [3.9]	2.58	13,400 [3.9]	9.50			
			2	UGGD-07?MCK?	17,850 [5.2]	6,150 [1.8]	24,000 [7.0]	17.00	12.75	800 [378]	74	22,200 [6.5]	3.82	9,900 [2.9]	2.56	22,200 [6.5]	2.56	13,400 [3.9]	2.56	22,200 [6.5]	2.56	13,400 [3.9]	2.56	13,400 [3.9]	9.50			
			1	UGJD-06?MCK?	14,450 [4.2]	4,150 [1.2]	24,000 [7.0]	17.00	12.90	600 [283]	71	16,500 [4.8]	3.84	9,800 [2.9]	2.58	22,200 [6.5]	2.58	13,400 [3.9]	2.58	22,200 [6.5]	2.58	13,400 [3.9]	2.58	13,400 [3.9]	9.50			
			2	UGJD-07?MCK?	17,850 [5.2]	6,150 [1.8]	24,000 [7.0]	17.00	12.75	800 [378]	74	22,200 [6.5]	3.82	9,900 [2.9]	2.56	22,200 [6.5]	2.56	13,400 [3.9]	2.56	22,200 [6.5]	2.56	13,400 [3.9]	2.56	13,400 [3.9]	9.50			
			024JEZ	RCFM-H*2421A*		1	UGLR-07?AMK?	14,500 [4.2]	4,100 [1.2]	24,000 [7.0]	17.00	13.05	600 [283]	71	16,500 [4.8]	3.86	9,800 [2.9]	2.60	22,200 [6.5]	2.60	13,300 [3.9]	2.60	22,200 [6.5]	2.60	13,300 [3.9]	2.60	13,300 [3.9]	9.50
						2	UGPL-07?BRK?	17,900 [5.2]	6,100 [1.8]	24,000 [7.0]	17.00	12.95	800 [378]	74	22,200 [6.5]	3.84	9,800 [2.9]	2.58	22,200 [6.5]	2.58	13,400 [3.9]	2.58	22,200 [6.5]	2.58	13,400 [3.9]	2.58	13,400 [3.9]	9.50
						1	UGPR-05?BMK?	14,400 [4.2]	4,100 [1.2]	24,000 [7.0]	16.50	12.80	600 [283]	71	16,600 [4.9]	3.82	9,900 [2.9]	2.58	22,200 [6.5]	2.58	13,400 [3.9]	2.58	22,200 [6.5]	2.58	13,400 [3.9]	2.58	13,400 [3.9]	9.50
						2	UGPR-07?AMK?	17,850 [5.2]	6,150 [1.8]	24,000 [7.0]	17.00	12.95	775 [366]	74	22,200 [6.5]	3.84	9,800 [2.9]	2.58	22,200 [6.5]	2.58	13,400 [3.9]	2.58	22,200 [6.5]	2.58	13,400 [3.9]	2.58	13,400 [3.9]	9.50
1	Coil Only	13,900 [4.1]				4,100 [1.2]	23,600 [6.9]	14.50	11.65	625 [295]	71	17,100 [5.0]	3.58	10,400 [3.0]	2.44	22,800 [6.7]	2.44	13,900 [4.1]	2.44	22,800 [6.7]	2.44	13,900 [4.1]	2.44	13,900 [4.1]	8.50			
2	Coil Only	17,450 [5.1]				6,150 [1.8]	23,600 [6.9]	14.50	11.65	775 [366]	74	22,800 [6.7]	3.58	13,900 [4.1]	2.44	22,800 [6.7]	2.44	13,900 [4.1]	2.44	22,800 [6.7]	2.44	13,900 [4.1]	2.44	13,900 [4.1]	8.50			

[ ] Designates Metric Conversions

# Performance Data ARI Standard Conditions (con't.)

Note: Only these combinations of indoor/outdoor units are approved and any other combinations should not be used.

Outdoor Unit UPRL-	Model Numbers	Stage	ARI Cooling Performance						ARI Heating Performance (70°F [21°C] Indoor)						DOE Region IV HSPF		
			80° [26.5°C] / 67°F [19.5°C] WB Indoor Air			95°F [35°C] DB Outdoor Air			Outdoor Air			Outdoor Air				17°F [-8.5°C] DB / 15°F [-9.5°C] WB	
			Net Sensible BTU/H [kW]	Net Latent BTU/H [kW]	Total Capacity	SEER	EER	Indoor Airflow CFM [L/s]	Sound Rating dB	47°F [8.5°C] DB / 43°F [6°C] WB	COP	BTU/H [kW]	17°F [-8.5°C] DB / 15°F [-9.5°C] WB	BTU/H [kW]			COP
Rev. 3/28/2008	RCSM-H*3621A* ①	1	19,350 [5.7]	6,450 [1.9]				875 [413]	71	24,000 [7.0]	3.68	14,900 [4.4]	2.38	33,400 [9.8]	21,400 [6.3]	8.70	
		2	25,700 [7.5]	9,700 [2.8]	35,400 [10.4]	16.50	12.75	1200 [566]	72	33,400 [9.8]	3.68	21,400 [6.3]	2.38				
		1 - dehumid	16,050 [4.7]	2,650 [0.8]				750 [354]	71								
		2 - dehumid	23,000 [6.7]	6,800 [2.0]				950 [448]	72								
		1	19,000 [5.6]	6,400 [1.9]	34,600 [10.1]	15.00	11.50	875 [413]	71	24,400 [7.1]	3.48	15,300 [4.5]	2.38	34,000 [10.0]	22,200 [6.5]	22,200 [6.5]	8.25
		2	25,100 [7.4]	9,500 [2.8]				1175 [554]	72	34,000 [10.0]	3.46	22,200 [6.5]	2.38				
		1	19,050 [5.6]	6,350 [1.9]	34,400 [10.1]	15.00	11.40	900 [425]	71	24,400 [7.1]	3.46	15,200 [4.5]	2.38	34,200 [10.0]	22,200 [6.5]	22,200 [6.5]	8.70
		2	25,050 [7.3]	9,350 [2.7]				1200 [566]	72	34,200 [10.0]	3.46	22,200 [6.5]	2.38				
036JEZ	RCFM-H*3617A*	1	19,100 [5.6]	6,300 [1.8]	34,600 [10.1]	15.50	11.55	900 [425]	71	24,200 [7.1]	3.50	15,100 [4.4]	2.40	34,000 [10.0]	22,000 [6.4]	22,000 [6.4]	8.70
		2	25,150 [7.4]	9,450 [2.8]				1225 [578]	72	34,000 [10.0]	3.48	22,000 [6.5]	2.38				
		1	19,050 [5.6]	6,350 [1.9]	34,600 [10.1]	15.00	11.45	925 [437]	71	24,200 [7.1]	3.48	15,200 [4.5]	2.38	34,000 [10.0]	22,200 [6.5]	22,200 [6.5]	8.70
		2	25,050 [7.3]	9,550 [2.8]				1225 [578]	72	34,000 [10.0]	3.48	22,200 [6.5]	2.38				
		1	19,100 [5.6]	6,300 [1.8]	34,600 [10.1]	15.50	11.55	900 [425]	71	24,200 [7.1]	3.50	15,100 [4.4]	2.40	34,000 [10.0]	22,000 [6.4]	22,000 [6.4]	8.70
		2	25,150 [7.4]	9,450 [2.8]				1225 [578]	72	34,000 [10.0]	3.48	22,000 [6.5]	2.38				
		1	19,050 [5.6]	6,350 [1.9]	34,600 [10.1]	15.00	11.45	925 [437]	71	24,200 [7.1]	3.48	15,200 [4.5]	2.38	34,000 [10.0]	22,200 [6.5]	22,200 [6.5]	8.70
		2	25,050 [7.3]	9,550 [2.8]				1225 [578]	72	34,000 [10.0]	3.48	22,200 [6.5]	2.38				
	UGFD-067MCK?	1	19,200 [5.6]	6,400 [1.9]	35,000 [10.3]	16.00	12.00	925 [437]	71	24,200 [7.1]	3.58	15,000 [4.4]	2.44	33,800 [9.9]	21,800 [6.4]	21,800 [6.4]	8.70
		2	25,350 [7.4]	9,650 [2.8]				1200 [566]	72	33,800 [9.9]	3.58	21,800 [6.4]	2.44				
		1	19,000 [5.6]	6,400 [1.9]	34,600 [10.1]	15.00	11.50	900 [425]	71	24,400 [7.1]	3.48	15,300 [4.5]	2.38	34,000 [10.0]	22,000 [6.4]	22,000 [6.4]	8.25
		2	25,100 [7.4]	9,500 [2.8]				1200 [566]	72	34,000 [10.0]	3.48	22,000 [6.4]	2.38				
		1	18,150 [5.3]	6,450 [1.9]	34,200 [10.0]	14.00	11.85	875 [413]	71	24,800 [7.3]	3.52	15,600 [4.6]	2.40	33,200 [9.7]	21,600 [6.3]	21,600 [6.3]	8.25
		2	24,700 [7.2]	9,500 [2.8]				1070 [505]	72	33,200 [9.7]	3.52	21,600 [6.3]	2.40				
		1	19,000 [5.6]	6,400 [1.9]	34,600 [10.1]	15.00	11.50	900 [425]	71	24,400 [7.1]	3.48	15,300 [4.5]	2.38	34,000 [10.0]	22,000 [6.4]	22,000 [6.4]	8.25
		2	25,100 [7.4]	9,500 [2.8]				1200 [566]	72	34,000 [10.0]	3.48	22,000 [6.4]	2.38				
	RCFM-H*3617A*+RXMD-C06	1	18,150 [5.3]	6,450 [1.9]	34,200 [10.0]	14.00	11.85	875 [413]	71	24,800 [7.3]	3.52	15,600 [4.6]	2.40	33,200 [9.7]	21,600 [6.3]	21,600 [6.3]	8.25
		2	24,700 [7.2]	9,500 [2.8]				1070 [505]	72	33,200 [9.7]	3.52	21,600 [6.3]	2.40				

① Highest sales volume tested combination required by DOE test procedures.

[ ] Designates Metric Conversions

# Performance Data ARI Standard Conditions (con't.)

Note: Only these combinations of indoor/outdoor units are approved and any other combinations should not be used.

Outdoor Unit UPRL-	Model Numbers		Stage	ARI Cooling Performance 80° [26.5°C] / 67°F [19.5°C] WB Indoor Air 95°F [35°C] DB Outdoor Air						ARI Heating Performance 70°F [21°C] Indoor						DOE Region IV HSPF						
	ID Coil	ID Air Mover		Net Sensible BTU/H [kW]	Net Latent BTU/H [kW]	ARI Ratings		Indoor Airflow CFM [L/s]	Sound Rating dB	Outdoor Air 47°F [8.5°C] DB/ 43°F [6°C] WB	COP	BTU/H [kW]	47°F [8.5°C] DB/ 43°F [6°C] WB	COP	BTU/H [kW]		17°F [-8.5°C] DB/ 15°F [-9.5°C] WB					
						Total Capacity	SEER											EER	BTU/H [kW]	BTU/H [kW]		
Rev. 3/28/2008				1	19,250 [5.6]	6,350 [1.9]	34,800 [10.2]	16.00	12.30	850 [401]	71	24,000 [7.0]	3.64	14,900 [4.4]	2.48	33,400 [9.8]	21,600 [6.3]	8.70				
				2	25,300 [7.4]	9,500 [2.8]				1150 [543]	72	33,400 [9.8]				21,600 [6.3]						
				1	19,250 [5.6]	6,350 [1.9]	35,000 [10.3]	16.00	12.20	850 [401]	71	24,000 [7.0]	3.62	15,000 [4.4]	2.46	21,600 [6.3]	2.46	33,600 [9.8]	21,600 [6.3]	8.70		
				2	25,450 [7.5]	9,550 [2.8]				1175 [554]	72	33,600 [9.8]				21,600 [6.3]						
				1	19,300 [5.7]	6,500 [1.9]	35,200 [10.3]	16.50	12.35	800 [378]	71	24,000 [7.0]	3.64	14,900 [4.4]	2.48	21,600 [6.3]	2.48	33,400 [9.8]	21,600 [6.3]	8.70		
				2	25,500 [7.5]	9,700 [2.8]				1175 [554]	72	33,400 [9.8]				21,600 [6.3]						
				1	19,300 [5.7]	6,500 [1.9]	35,200 [10.3]	16.50	12.40	825 [389]	71	24,000 [7.0]	3.64	14,900 [4.4]	2.48	21,600 [6.3]	2.48	33,400 [9.8]	21,600 [6.3]	8.70		
				2	25,550 [7.5]	9,650 [2.8]				1175 [554]	72	33,400 [9.8]				21,600 [6.3]						
				036LEZ				1	19,300 [5.7]	6,500 [1.9]	35,200 [10.3]	16.50	12.35	800 [378]	71	24,000 [7.0]	3.64	14,900 [4.4]	2.48	33,400 [9.8]	21,600 [6.3]	8.70
								2	25,500 [7.5]	9,700 [2.8]				1175 [554]	72	33,400 [9.8]				21,600 [6.3]		
1	19,300 [5.7]	6,500 [1.9]	35,200 [10.3]					16.50	12.40	825 [389]	71	24,000 [7.0]	3.64	14,900 [4.4]	2.48	21,600 [6.3]	2.48	33,400 [9.8]	21,600 [6.3]	8.70		
2	25,550 [7.5]	9,650 [2.8]								1175 [554]	72	33,400 [9.8]				21,600 [6.3]						
1	19,250 [5.6]	6,350 [1.9]	35,200 [10.3]					16.00	12.55	925 [437]	71	24,000 [7.0]	3.66	14,900 [4.4]	2.48	21,600 [6.3]	2.48	33,400 [9.8]	21,400 [6.3]	8.70		
2	25,600 [7.5]	9,600 [2.8]								1200 [566]	72	33,400 [9.8]				21,400 [6.3]						
1	19,150 [5.6]	6,450 [1.9]	35,000 [10.3]					15.50	12.00	900 [425]	71	24,200 [7.1]	3.58	15,100 [4.4]	2.44	21,800 [6.4]	2.44	33,800 [9.9]	21,800 [6.4]	8.70		
2	25,350 [7.4]	9,650 [2.8]								1200 [566]	72	33,800 [9.9]				21,800 [6.4]						
1	19,300 [5.7]	6,500 [1.9]	35,200 [10.3]					16.50	12.55	875 [413]	71	24,000 [7.0]	3.66	14,900 [4.4]	2.50	21,400 [6.3]	2.50	33,400 [9.8]	21,400 [6.3]	8.70		
2	25,600 [7.5]	9,600 [2.8]								1200 [566]	72	33,400 [9.8]				21,400 [6.3]						
RCFM-H*3621A *				1	19,200 [5.6]	6,400 [1.9]	35,200 [10.3]	16.00	12.30	925 [437]	71	24,000 [7.0]	3.64	15,000 [4.4]	2.46	33,600 [9.8]	21,600 [6.3]	8.70				
				2	25,500 [7.5]	9,700 [2.8]				1225 [578]	72	33,600 [9.8]			21,600 [6.3]							
				1	18,350 [5.4]	6,450 [1.9]	34,400 [10.1]	14.50	11.70	875 [413]	71	24,800 [7.3]	3.50	15,600 [4.6]	2.38	33,800 [9.9]	21,800 [6.4]	8.25				
				2	24,800 [7.3]	9,600 [2.8]				1150 [543]	72	33,800 [9.9]			21,800 [6.4]							

[ ] Designates Metric Conversions

## Performance Data ARI Standard Conditions (con't.)

Note: Only these combinations of indoor/outdoor units are approved and any other combinations should not be used.

Outdoor Unit UPRL-	Model Numbers		Stage	ARI Cooling Performance 80° [26.5°C] / 67°F [19.5°C] WB Indoor Air 95°F [35°C] DB Outdoor Air				ARI Heating Performance (70°F [21°C] Indoor)				DOE Region IV HSPF					
	ID Coil	ID Air Mover		Net Sensible BTU/H [kW]	Net Latent BTU/H [kW]	ARI Ratings		Indoor Airflow CFM [L/s]	Sound Rating dB	Outdoor Air			COP				
						Total Capacity	SEER			EER	BTU/H [kW]			COP	BTU/H [kW]	BTU/H [kW]	17°F [-8.5°C] DB/ 15°F [-9.5°C] WB
Rev. 3/28/2008	RCSM-H* 4824A ①	UHPL-HM4824	1	26,650 [7.8]	8,750 [2.6]	1200 [566]	71	33,200 [9.7]	3.66	18,500 [5.4]	2.54	44,500 [13.0]	26,200 [7.7]	9.50			
			2	35,100 [10.3]	11,900 [3.5]	1625 [767]	72	44,500 [13.0]	3.66	26,200 [7.7]	2.54	44,500 [13.0]	26,200 [7.7]	9.50			
			1 - dehumid	24,000 [7.0]	9,800 [2.9]	1000 [472]	71										
			2 - dehumid	33,450 [9.8]	14,050 [4.1]	1275 [602]	72										
			1	26,300 [7.7]	8,700 [2.5]	1150 [543]	71	46,000 [13.5]	14.50	11.20	33,600 [9.8]	3.96	18,900 [5.5]	2.42	45,500 [13.3]	27,000 [7.9]	9.00
			2	34,500 [10.1]	11,500 [3.4]	1600 [755]	72	46,000 [13.5]	14.00	10.90	45,500 [13.3]	3.88	19,000 [5.6]	2.38	45,500 [13.3]	27,400 [8.0]	9.00
			1	26,250 [7.7]	8,550 [2.5]	1175 [554]	71	46,000 [13.5]	14.50	11.00	33,600 [9.8]	3.88	18,900 [5.5]	2.38	45,500 [13.3]	27,400 [8.0]	9.00
			2	34,250 [10.0]	11,750 [3.4]	1625 [767]	72	46,000 [13.5]	14.50	11.05	45,500 [13.3]	3.88	18,900 [5.5]	2.38	45,500 [13.3]	27,400 [8.0]	9.00
048JEZ	RCSM-H* 4821A*	UGFD-107ZCM?	1	26,300 [7.7]	8,700 [2.5]	1175 [554]	71	33,600 [9.8]	3.92	18,900 [5.5]	2.40	45,500 [13.3]	27,200 [8.0]	9.00			
			2	34,350 [10.1]	11,650 [3.4]	1625 [767]	72	45,500 [13.3]	14.50	11.05	33,600 [9.8]	3.88	18,900 [5.5]	2.38	45,500 [13.3]	27,400 [8.0]	9.00
			1	26,300 [7.7]	8,700 [2.5]	1175 [554]	71	46,000 [13.5]	14.50	11.00	33,600 [9.8]	3.88	18,900 [5.5]	2.38	45,500 [13.3]	27,400 [8.0]	9.00
			2	34,450 [10.1]	11,550 [3.4]	1675 [790]	72	46,000 [13.5]	14.50	11.05	45,500 [13.3]	3.92	18,900 [5.5]	2.40	45,500 [13.3]	27,200 [8.0]	9.00
			1	26,300 [7.7]	8,700 [2.5]	1175 [554]	71	46,000 [13.5]	14.50	11.00	33,600 [9.8]	3.88	18,900 [5.5]	2.38	45,500 [13.3]	27,400 [8.0]	9.00
			2	34,450 [10.1]	11,550 [3.4]	1675 [790]	72	46,000 [13.5]	14.50	11.05	45,500 [13.3]	3.92	18,900 [5.5]	2.40	45,500 [13.3]	27,200 [8.0]	9.00
			1	26,300 [7.7]	8,700 [2.5]	1175 [554]	71	46,000 [13.5]	14.50	11.00	33,600 [9.8]	3.88	18,900 [5.5]	2.38	45,500 [13.3]	27,400 [8.0]	9.00
			2	34,450 [10.1]	11,550 [3.4]	1675 [790]	72	46,000 [13.5]	14.50	11.05	45,500 [13.3]	3.92	18,900 [5.5]	2.40	45,500 [13.3]	27,200 [8.0]	9.00
	RCSM-H* 4821A*	UGLD-107ZCM?	1	26,300 [7.7]	8,700 [2.5]	1200 [566]	71	33,400 [9.8]	4.06	18,800 [5.5]	2.46	45,000 [13.2]	26,800 [7.9]	9.00			
			2	34,550 [10.1]	11,950 [3.5]	1575 [743]	72	45,000 [13.2]	14.50	11.55	33,400 [9.8]	4.06	26,800 [7.9]	26,800 [7.9]	9.00		
			1	26,400 [7.7]	8,600 [2.5]	1225 [578]	71	46,500 [13.6]	14.50	11.60	33,400 [9.8]	4.06	18,800 [5.5]	2.46	45,000 [13.2]	26,800 [7.9]	9.00
			2	34,750 [10.2]	11,750 [3.4]	1625 [767]	72	46,500 [13.6]	14.50	11.35	45,000 [13.2]	4.00	26,800 [7.9]	2.44	45,000 [13.2]	27,000 [7.9]	9.00
			1	26,300 [7.7]	8,700 [2.5]	1200 [566]	71	46,500 [13.6]	14.50	11.35	33,600 [9.8]	4.00	18,800 [5.5]	2.44	45,000 [13.2]	27,000 [7.9]	9.00
			2	34,600 [10.1]	11,900 [3.5]	1625 [767]	72	46,500 [13.6]	14.50	11.45	45,000 [13.2]	3.98	19,500 [5.7]	2.44	44,500 [13.0]	26,600 [7.8]	8.50
			1	25,050 [7.3]	8,750 [2.6]	1200 [566]	71	45,500 [13.3]	13.50	11.45	34,200 [10.0]	3.98	19,500 [5.7]	2.44	44,500 [13.0]	26,600 [7.8]	8.50
			2	33,800 [9.9]	11,700 [3.4]	1475 [696]	72	45,500 [13.3]	13.50	11.45	44,500 [13.0]	3.98	26,600 [7.8]	2.44	44,500 [13.0]	26,600 [7.8]	8.50

① Highest sales volume tested combination required by DOE test procedures.

[ ] Designates Metric Conversions



# Performance Data ARI Standard Conditions (con't.)

Note: Only these combinations of indoor/outdoor units are approved and any other combinations should not be used.

Outdoor Unit UPRL-	Model Numbers		Stage	ARI Cooling Performance 80° [26.5°C] / 67°F [19.5°C] WB Indoor Air 95°F [35°C] DB Outdoor Air						ARI Heating Performance (70°F [21°C] Indoor)						DOE Region IV HSPF		
	ID Coil	ID Air Mover		Net Sensible BTU/H [kW]	Net Latent BTU/H [kW]	ARI Ratings		Indoor Airflow CFM [L/s]	Sound Rating dB	Outdoor Air 47°F [8.5°C] DB/ 43°F [6°C] WB		Outdoor Air 17°F [-8.5°C] DB/ 15°F [-9.5°C] WB		47°F [8.5°C] DB/ 43°F [6°C] WB			17°F [-8.5°C] DB/ 15°F [-9.5°C] WB	
						Total Capacity	EER			SEER	EER	BTU/H [kW]	COP	BTU/H [kW]	COP		BTU/H [kW]	COP
Rev. 3/28/2008			1	UGFD-09?ZCM?	26,300 [7.7]	8,700 [2.5]	46,000 [13.5]	14.50	11.20	1150 [543]	71	33,600 [9.8]	3.96	18,900 [5.5]	2.42	45,500 [13.3]	27,000 [7.9]	9.00
			2	UGFD-10?ZCM?	34,500 [10.1]	11,500 [3.4]	46,000 [13.5]	14.00	10.90	1600 [755]	72	45,500 [13.3]	3.88	19,000 [5.6]	2.38	45,500 [13.3]	27,400 [8.0]	9.00
			1	UGFD-10?ZCM?	26,250 [7.7]	8,550 [2.5]	46,500 [13.6]	14.50	11.45	1175 [554]	71	33,600 [9.8]	4.00	18,900 [5.5]	2.44	45,000 [13.2]	27,000 [7.9]	9.00
			2	UGFD-12?RCM?	34,250 [10.0]	11,750 [3.4]	46,000 [13.5]	14.50	11.00	1625 [767]	72	45,000 [13.2]	3.88	18,900 [5.5]	2.38	45,500 [13.3]	27,400 [8.0]	9.00
			1	UGGD-09?ZCM?	26,250 [7.7]	8,550 [2.5]	46,000 [13.5]	14.50	11.05	1225 [578]	71	33,600 [9.8]	3.92	18,800 [5.5]	2.42	45,500 [13.3]	27,200 [8.0]	9.00
			2	UGGD-10?ZCM?	34,650 [10.2]	11,850 [3.5]	46,000 [13.5]	14.50	11.25	1650 [779]	72	45,500 [13.3]	3.88	18,900 [5.5]	2.38	45,500 [13.3]	27,400 [8.0]	9.00
			1	UGGD-09?ZCM?	26,300 [7.7]	8,700 [2.5]	46,000 [13.5]	14.50	11.00	1175 [554]	71	33,600 [9.8]	3.92	18,800 [5.5]	2.42	45,500 [13.3]	27,200 [8.0]	9.00
			2	UGGD-10?ZCM?	34,450 [10.1]	11,550 [3.4]	46,000 [13.5]	14.50	11.05	1675 [790]	72	45,500 [13.3]	3.88	18,900 [5.5]	2.38	45,500 [13.3]	27,400 [8.0]	9.00
			1	UGGD-10?ZCM?	26,300 [7.7]	8,700 [2.5]	46,000 [13.5]	14.50	11.05	1175 [554]	71	33,600 [9.8]	3.92	18,800 [5.5]	2.42	45,500 [13.3]	27,200 [8.0]	9.00
			2	UGGD-12?RCM?	34,350 [10.1]	11,650 [3.4]	46,000 [13.5]	14.50	11.25	1625 [767]	72	45,500 [13.3]	3.88	18,900 [5.5]	2.38	45,500 [13.3]	27,400 [8.0]	9.00
048JEZ		RCFM-H*4824A*	1	UGJD-09?ZCM?	26,300 [7.7]	8,700 [2.5]	46,000 [13.5]	14.50	11.00	1175 [554]	71	33,600 [9.8]	3.92	18,900 [5.5]	2.40	45,500 [13.3]	27,200 [8.0]	9.00
			2	UGJD-10?ZCM?	34,450 [10.1]	11,550 [3.4]	46,000 [13.5]	14.50	11.05	1675 [790]	72	45,500 [13.3]	3.92	18,900 [5.5]	2.40	45,500 [13.3]	27,200 [8.0]	9.00
			1	UGJD-10?ZCM?	26,300 [7.7]	8,700 [2.5]	46,000 [13.5]	14.50	11.05	1175 [554]	71	33,600 [9.8]	3.96	18,800 [5.5]	2.42	45,500 [13.3]	27,000 [7.9]	9.00
			2	UGJD-12?RCM?	34,350 [10.1]	11,650 [3.4]	46,000 [13.5]	14.50	11.25	1625 [767]	72	45,500 [13.3]	4.06	18,800 [5.5]	2.46	45,000 [13.2]	26,800 [7.8]	9.00
			1	UGLR-10?BRM?	26,400 [7.7]	8,600 [2.5]	46,500 [13.6]	14.50	11.55	1200 [566]	71	33,400 [9.8]	4.06	18,800 [5.5]	2.48	45,000 [13.2]	26,600 [7.8]	9.00
			2	UGLR-12?ARM?	34,550 [10.1]	11,950 [3.5]	46,500 [13.6]	14.50	11.65	1575 [743]	72	45,000 [13.2]	4.06	18,800 [5.5]	2.46	45,000 [13.2]	26,800 [7.9]	9.00
			1	UGPR-07?BRQ?	26,400 [7.7]	8,600 [2.5]	46,500 [13.6]	14.50	11.65	1200 [566]	71	33,400 [9.8]	4.06	18,800 [5.5]	2.44	45,000 [13.2]	27,000 [7.9]	9.00
			2	UGPR-10?ZCM?	34,800 [10.2]	11,700 [3.4]	46,500 [13.6]	14.50	11.60	1600 [755]	72	45,000 [13.2]	4.06	18,800 [5.5]	2.44	45,000 [13.2]	27,000 [7.9]	9.00
			1	UGPR-10?ZCM?	26,400 [7.7]	8,600 [2.5]	46,500 [13.6]	14.50	11.60	1225 [578]	71	33,400 [9.8]	4.06	18,800 [5.5]	2.44	45,000 [13.2]	27,000 [7.9]	9.00
			2	UGPR-12?ARM?	34,750 [10.2]	11,750 [3.4]	46,500 [13.6]	14.50	11.35	1625 [767]	72	45,000 [13.2]	4.06	18,800 [5.5]	2.44	45,000 [13.2]	27,000 [7.9]	9.00
		RCFM-H*4824A*+RXMD-C06	1	Coil Only	25,050 [7.3]	8,750 [2.6]	45,500 [13.3]	13.50	11.45	1200 [566]	71	34,200 [10.0]	3.98	19,500 [5.7]	2.44	44,500 [13.0]	26,600 [7.8]	8.50
			2	Coil Only	33,800 [9.9]	11,700 [3.4]	45,500 [13.3]	13.50	11.45	1475 [696]	72	44,500 [13.0]	3.98	26,600 [7.8]	2.44	44,500 [13.0]	26,600 [7.8]	8.50

[ ] Designates Metric Conversions

# Performance Data ARI Standard Conditions (con't.)

Note: Only these combinations of indoor/outdoor units are approved and any other combinations should not be used.

Outdoor Unit UPRL-	Model Numbers		Stage	ARI Cooling Performance 80° [26.5°C] / 67°F [19.5°C] WB Indoor Air 95°F [35°C] DB Outdoor Air						ARI Heating Performance 70°F [21°C] Indoor						DOE Region IV HSPF		
	ID Coil	ID Air Mover		Net Sensible BTU/H [kW]	Net Latent BTU/H [kW]	ARI Ratings		Indoor Airflow CFM [L/s]	Sound Rating dB	Outdoor Air 47°F [8.5°C] DB/ 43°F [6°C] WB		Outdoor Air 17°F [-8.5°C] DB/ 15°F [-9.5°C] WB		Outdoor Air 47°F [8.5°C] DB/ 43°F [6°C] WB			Outdoor Air 17°F [-8.5°C] DB/ 15°F [-9.5°C] WB	
						Total Capacity	SEER			EER	BTU/H [kW]	COP	BTU/H [kW]	COP	BTU/H [kW]		COP	BTU/H [kW]
Rev. 3/28/2008	RCSM-H*6024A ①	UHPL-HM6024	1	31,900 [9.3]	11,300 [3.3]			1375 [649]	76	43,000 [12.6]	3.78	26,600 [7.8]	2.74	58,000 [17.0]	36,800 [10.8]	9.00		
			2	41,000 [12.0]	17,000 [5.0]	58,000 [17.0]	15.50	12.15	1675 [790]	78	58,000 [17.0]	3.78	36,800 [10.8]	2.74	58,000 [17.0]	36,800 [10.8]	9.00	
			1 - dehumid	29,550 [8.7]	12,550 [3.7]			1125 [531]	76									
			2 - dehumid	37,850 [11.1]	18,950 [5.6]			1350 [637]	78									
		UGFD-09ZCM?	1	31,800 [9.3]	11,200 [3.3]	57,000 [16.7]	15.00	11.45	1150 [543]	76	43,000 [12.6]	3.66	26,800 [7.9]	2.66	58,500 [17.1]	37,400 [11.0]	9.00	
		UGFD-10ZCM?	2	40,200 [11.8]	16,800 [4.9]	57,000 [16.7]	15.00	11.20	1600 [755]	78	58,500 [17.1]	3.62	26,800 [7.9]	2.62	59,000 [17.3]	37,600 [11.0]	9.00	
		UGFD-12?RCM?	1	31,700 [9.3]	11,300 [3.3]	57,000 [16.7]	15.00	11.20	1175 [554]	76	43,000 [12.6]	3.62	26,800 [7.9]	2.62	59,000 [17.3]	37,600 [11.0]	9.00	
		UGFD-12?RCM?	2	40,100 [11.7]	16,900 [5.0]	57,500 [16.8]	15.00	11.70	1625 [767]	78	59,000 [17.3]	3.68	26,800 [7.9]	2.68	58,500 [17.1]	37,200 [10.9]	9.00	
		UGGD-09ZCM?	1	31,750 [9.3]	11,250 [3.3]	57,000 [16.7]	15.00	11.35	1225 [578]	76	43,000 [12.6]	3.62	26,800 [7.9]	2.64	59,000 [17.3]	37,600 [11.0]	9.00	
		UGGD-09ZCM?	2	40,700 [11.9]	16,800 [4.9]	57,000 [16.7]	15.00	11.35	1650 [779]	78	58,500 [17.1]	3.62	26,800 [7.9]	2.64	59,000 [17.3]	37,600 [11.0]	9.00	
		UGGD-10ZCM?	1	31,800 [9.3]	11,200 [3.3]	57,000 [16.7]	15.00	11.35	1175 [554]	76	43,000 [12.6]	3.64	26,800 [7.9]	2.64	58,500 [17.1]	37,400 [11.0]	9.00	
		UGGD-10ZCM?	2	40,400 [11.8]	16,600 [4.9]	57,000 [16.7]	15.00	11.35	1675 [790]	78	59,000 [17.3]	3.64	26,800 [7.9]	2.64	58,500 [17.1]	37,400 [11.0]	9.00	
		UGGD-12?RCM?	1	31,800 [9.3]	11,200 [3.3]	57,500 [16.8]	15.00	11.60	1175 [554]	76	43,000 [12.6]	3.68	26,600 [7.8]	2.66	58,500 [17.1]	37,400 [11.0]	9.00	
		UGGD-12?RCM?	2	40,600 [11.9]	16,900 [5.0]	57,500 [16.8]	15.00	11.60	1625 [767]	78	58,500 [17.1]	3.68	26,600 [7.8]	2.66	58,500 [17.1]	37,400 [11.0]	9.00	
060JEZ	RCFM-H*6024A*	UGJD-09ZCM?	1	31,800 [9.3]	11,200 [3.3]	57,000 [16.7]	15.00	11.35	1175 [554]	76	43,000 [12.6]	3.62	26,800 [7.9]	2.64	59,000 [17.3]	37,600 [11.0]	9.00	
		UGJD-09ZCM?	2	40,400 [11.8]	16,600 [4.9]	57,000 [16.7]	15.00	11.35	1675 [790]	78	59,000 [17.3]	3.62	26,800 [7.9]	2.64	59,000 [17.3]	37,600 [11.0]	9.00	
		UGJD-10ZCM?	1	31,800 [9.3]	11,200 [3.3]	57,000 [16.7]	15.00	11.35	1175 [554]	76	43,000 [12.6]	3.64	26,800 [7.9]	2.64	58,500 [17.1]	37,400 [11.0]	9.00	
		UGJD-10ZCM?	2	40,250 [11.8]	16,750 [4.9]	57,000 [16.7]	15.00	11.35	1625 [767]	78	58,500 [17.1]	3.64	26,800 [7.9]	2.64	58,500 [17.1]	37,400 [11.0]	9.00	
		UGJD-12?RCM?	1	31,800 [9.3]	11,200 [3.3]	57,500 [16.8]	15.00	11.60	1225 [578]	76	43,000 [12.6]	3.68	26,600 [7.8]	2.66	58,500 [17.1]	37,400 [11.0]	9.00	
		UGJD-12?RCM?	2	40,600 [11.9]	16,900 [5.0]	57,500 [16.8]	15.00	11.60	1650 [779]	78	58,500 [17.1]	3.68	26,600 [7.8]	2.66	58,500 [17.1]	37,400 [11.0]	9.00	
		UGLR-10?BRM?	1	31,900 [9.3]	11,100 [3.3]	57,000 [16.7]	15.50	11.75	1200 [566]	76	43,000 [12.6]	3.74	26,600 [7.8]	2.70	58,000 [17.0]	37,000 [10.8]	9.50	
		UGLR-10?BRM?	2	40,400 [11.8]	16,600 [4.9]	57,000 [16.7]	15.50	11.75	1575 [743]	78	58,000 [17.0]	3.74	26,600 [7.8]	2.72	58,000 [17.0]	37,000 [10.8]	9.50	
		UGLR-12?ARM?	1	31,900 [9.3]	11,100 [3.3]	57,500 [16.8]	15.50	11.85	1200 [566]	76	43,000 [12.6]	3.74	26,600 [7.8]	2.72	58,000 [17.0]	37,000 [10.8]	9.50	
		UGLR-12?ARM?	2	40,500 [11.9]	17,000 [5.0]	57,500 [16.8]	15.50	11.85	1600 [755]	78	58,000 [17.0]	3.74	26,600 [7.8]	2.70	58,000 [17.0]	37,000 [10.8]	9.50	
		UGPR-07?BRQ?	1	31,850 [9.3]	11,150 [3.3]	57,500 [16.8]	15.50	11.80	1225 [578]	76	43,000 [12.6]	3.72	26,600 [7.8]	2.70	58,000 [17.0]	37,000 [10.8]	9.50	
		UGPR-07?BRQ?	2	40,600 [11.9]	16,900 [5.0]	57,500 [16.8]	15.50	11.80	1625 [767]	78	58,000 [17.0]	3.72	26,600 [7.8]	2.70	58,000 [17.0]	37,000 [10.8]	9.50	
		UGPR-10?BRM?	1	31,800 [9.3]	11,200 [3.3]	57,000 [16.7]	15.00	11.60	1200 [566]	76	43,000 [12.6]	3.70	26,600 [7.8]	2.68	58,500 [17.1]	37,200 [10.9]	9.00	
		UGPR-10?BRM?	2	40,450 [11.9]	16,550 [4.8]	57,000 [16.7]	15.00	11.60	1625 [767]	78	58,500 [17.1]	3.70	26,600 [7.8]	2.68	58,500 [17.1]	37,200 [10.9]	9.00	
		UGPR-12?ARM?	1	31,850 [9.3]	11,150 [3.3]	57,000 [16.7]	15.00	11.80	1250 [590]	76	43,000 [12.6]	3.74	26,600 [7.8]	2.72	58,000 [17.0]	37,000 [10.8]	9.00	
		UGPR-12?ARM?	2	40,400 [11.8]	16,600 [4.9]	57,000 [16.7]	15.00	11.80	1575 [743]	78	58,000 [17.0]	3.74	26,600 [7.8]	2.72	58,000 [17.0]	37,000 [10.8]	9.00	
		Coil Only	1	30,700 [9.0]	11,300 [3.3]	57,500 [16.8]	14.00	11.45	1375 [649]	76	44,000 [12.9]	3.64	27,600 [8.1]	2.64	59,000 [17.3]	37,600 [11.0]	9.00	
		Coil Only	2	40,500 [11.9]	17,000 [5.0]	57,500 [16.8]	14.00	11.45	1675 [790]	78	59,000 [17.3]	3.64	27,600 [8.1]	2.64	59,000 [17.3]	37,600 [11.0]	9.00	

① Highest sales volume tested combination required by DOE test procedures.

[ ] Designates Metric Conversions

# Electrical and Physical Data

Model Number UPRL-	ELECTRICAL							PHYSICAL					
	Phase Frequency (Hz) Voltage (Volts)	Compressor		Fan Motor Full Load Amperes (FLA)	Minimum Circuit Ampacity Amperes	Fuse or HACR Circuit Breaker		Outdoor Coil			R-410A Oz. [g]	Weight	
		Rated Load Amperes (RLA)	Locked Rotor Amperes (LRA)			Minimum Amperes	Maximum Amperes	Face Area Sq. Ft. [m <sup>2</sup> ]	No. Rows	CFM [L/s]		Net Lbs. [kg]	Shipping Lbs. [kg]
Rev. 3/28/2008													
024JEZ	1-60-208/230	10.3/10.3	52	0.5	14/14	20/20	20/20	23.00 [2.14]	1	HS* 2800 [1321] LS* 2300 [1085]	152 [4309]	256 [116.1]	266 [120.7]
036JEZ	1-60-208/230	16.7/16.7	82	1.0	22/22	30/30	35/35	22.22 [2.06]	2	HS* 3700 [1746] LS* 2800 [1321]	245 [6946]	319 [144.7]	329 [149.2]
048JEZ	1-60-208/230	21.2/21.2	96	1.0	28/28	35/35	45/45	22.22 [2.06]	2	HS* 3500 [1652] LS* 2800 [1321]	256 [7258]	308 [139.7]	318 [144.2]
060JEZ	1-60-208/230	25.6/25.6	118	1.1	34/34	40/40	50/50	22.22 [2.06]	2	3800 [1794]	284 [8051]	335 [152]	345 [156.5]

NOTES: \*HS = High Speed  
\*LS = Low Speed

## Unit Dimensions

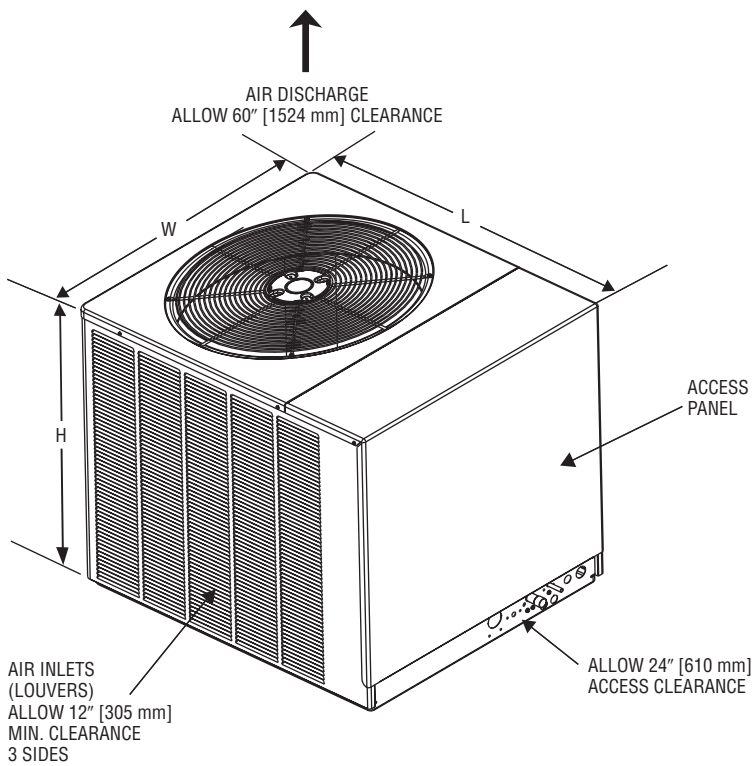

Model Number UPRL-	Height "H" (Inches) [mm]	Length "L" (Inches) [mm]	Width "W" (Inches) [mm]
024JEZ/036JEZ/ 048JEZ/060JEZ	33 [838]	44 <sup>3</sup> / <sub>8</sub> [1127]	31 <sup>1</sup> / <sub>2</sub> [800]

[ ] Designates Metric Conversions

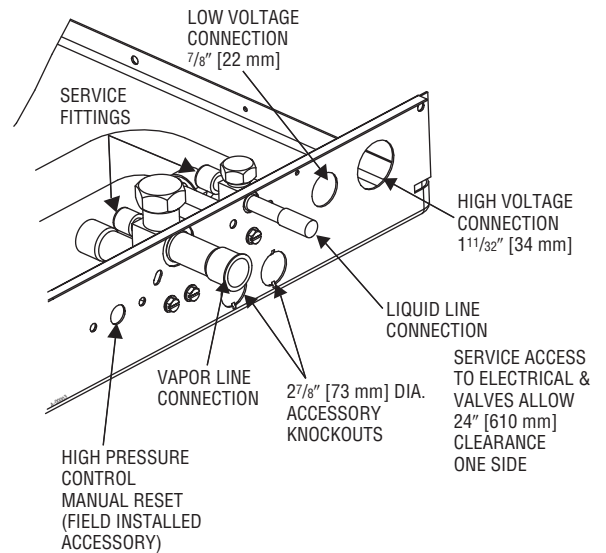

# Heat Pump Refrigerant Line Size Information

2-Stage R-410A System Capacity Model	Liquid Line Connection Size (Inch I.D.)	Liquid Line Connection Size (Inch O.D.) [mm]	Liquid Line Size Outdoor Unit Above or Below Indoor Coil						
			Total Equivalent Length—Feet [m]						
			25 [7.62]	50 [15.24]	75 [22.86]	100 [30.48]	125 [38.10]	150 [45.72]	
Maximum Vertical Separation—Feet [m]									
2 Ton	5/16"	1/4* [6.35]	25 [7.62]	10 [3.05]	N/A	N/A	N/A	N/A	N/A
		5/16 [7.94]	25 [7.62]	50 [15.24]	40 [12.19]	35 [10.67]	29 [8.84]	22 [6.71]	
		3/8 [9.53]	25 [7.62]	50 [15.24]	45 [13.72]	42 [12.80]	39 [11.89]	37 [11.28]	
3 Ton	5/16"	5/16* [7.94]	25 [7.62]	39 [11.89]	28 [8.53]	16 [4.88]	5 [1.52]	N/A	
		3/8 [9.53]	25 [7.62]	50 [15.24]	51 [15.54]	48 [14.63]	44 [13.41]	40 [12.19]	
4 Ton	3/8"	5/16* [7.94]	25 [7.62]	15 [4.57]	N/A	N/A	N/A	N/A	
		3/8 [9.53]	25 [7.62]	47 [14.33]	40 [12.19]	32 [9.75]	24 [7.32]	17 [5.18]	
5 Ton	3/8"	3/8* [9.53]	25 [7.62]	41 [12.50]	30 [9.14]	20 [6.10]	10 [3.05]	0 [0.00]	
		1/2 [12.7]	25 [7.62]	50 [15.24]	56 [17.07]	54 [16.46]	52 [15.85]	50 [15.24]	

NOTES: N/A – Application not recommended.

\*Standard line size.

Suction Line Length/Size vs. Capacity Multiplier (2-Stage R-410A)					
Unit Size		2 Ton	3 Ton	4 Ton	5 Ton
Suction Line Connection Size		3/4" I.D.	3/4" I.D.	7/8" I.D.	7/8" I.D.
Suction Line Run—Feet [m]		5/8" [15.88 mm] O.D. Standard* 3/4" [19.05 mm] O.D. Optional	5/8" [15.88 mm] O.D. Optional 3/4" [19.05 mm] O.D. Standard*	3/4" [19.05 mm] O.D. Optional 7/8" [22.23 mm] O.D. Standard*	3/4" [19.05 mm] O.D. Optional 7/8" [22.23 mm] O.D. Standard*
25' [7.62]	Optional Standard Optional	— 1.00 1.00	.99 1.00 —	1.00 1.00 —	.99 1.00 —
50' [15.24]	Optional Standard Optional	— .99 1.00	.98 .99 —	.98 .99 —	.98 .99 —
100' [30.48]	Optional Standard Optional	— .97 .98	.95 .97 —	.95 .97 —	.94 .97 —
150' [45.72]	Optional Standard Optional	— .95 .97	.91 .95 —	.93 .95 —	.91 .95 —

NOTES: Using suction line larger than shown in chart will result in poor oil return and is not recommended.

\*Standard line size.

[ ] Designates Metric Conversions

## GENERAL TERMS OF LIMITED WARRANTY

Ruud will furnish a replacement for any part of this product which fails in normal use and service within the applicable period stated, in accordance with the terms of the limited warranty.

For Complete Details of the Limited Warranty, Including Applicable Terms and Conditions, See Your Local Installer or Contact the Manufacturer for a Copy.

### Limited Parts Warranty:

Ruud *Ultra Series™* equipment features a 10-year limited parts warranty.\*

\*This ten-year limited parts warranty is applicable only to single-phase products installed in residential applications.

### UPRL- JEZ Conditional Replacement Warranty:

Ruud will provide a replacement UPRL-JEZ Heat Pump to the original purchaser if the compressor fails within 10 years (providing the unit is installed with a new Ruud *Ultra Series™* Air Handler OR Ruud Indoor Coil with a Ruud *Ultra Series™* Gas Furnace, and is properly matched according to Ruud specifications), and if additional conditions are satisfied. See product warranty card for additional information.

Before proceeding with installation, refer to installation instructions packaged with each model, as well as complying with all Federal, State, Provincial, and Local codes, regulations, and practices.

**Ruud Heating,  
Cooling and  
Water Heating**

P.O. Box 17010, Fort Smith, AR 72917



"In keeping with its policy of continuous progress and product improvement, Ruud reserves the right to make changes without notice."